

特長 Feature





刃先の振れを限りなく「ゼロ」に調整できる画期的なホルダです。
Runout accuracy of the cutting edge can be adjusted as closely as to zero.

型式 Model	商品コード Code	Type	d	L	L ₁	L ₂	B	D	D ₁	L ₀	キャップ Nut	kg	-	コレット Collet	スパナ Spanner	レンチ Wrench
BT 30	- 60 3090 10706000	1	0.5 ~ 7.0	60	22 ~ 45	22	0 ~ 4	41	23	-	HDP-07A	0.6	32,000	FDC-07	S-0	L-3T
	- 75 3090 10707500			75		37						0.6	33,500			
	- 90 3090 10709000			90		52						0.7	34,000			
	- 105 3090 10710500			105		67						0.7	34,500			
	- 75 3090 10907500			75		37						0.7	32,000			
	- 90 3090 10909000			90		52						0.7	33,500			
	- 105 3090 10910500			105		67							34,500			
	- 90 3090 11209000			90		33						1.0	35,000			
	- 105 3090 11210500			105		48						1.1	36,000			
	- 90 3090 11609000			90		33						1.0	36,000			
- 105 3090 11610500	105	48	1.1	37,000												
- 120 3090 11612000	120	63		38,000												
BT 40	- 75 3090 30707500	1	0.5 ~ 7.0	75	27 ~ 57	32	0 ~ 4	41	23	-	HDP-07A	1.2	37,500	FDC-07	S-0	L-3T
	- 90 3090 30709000			90		47							38,000			
	- 105 3090 30710500			105		62							39,500			
	- 90 3090 30909000			90		47						1.3	37,500			
	- 105 3090 30910500			105		62							38,000			
	- 120 3090 30912000			120		77							39,000			
	- 135 3090 30913500			135		92							39,500			
	- 165 3090 30916500			165		122							40,500			
	- 90 3090 31209000			90		43						1.5	39,500			
	- 105 3090 31210500			105		58						1.6	40,000			
	- 120 3090 31212000			120		73						1.6	40,500			
	- 135 3090 31213500			135		88						1.7	41,500			
	- 165 3090 31216500			165		118							42,500			
	- 195 3090 31219500			195		148						2.0	43,500			
	- 90 3090 31609000			90		43						1.6	41,500			
	- 105 3090 31610500			105		58						1.7	42,000			
	- 120 3090 31612000			120		73						1.8	42,500			
	- 135 3090 31613500			135		88						1.9	43,000			
- 165 3090 31616500	165	118	2.1	44,500												
- 195 3090 31619500	195	148		45,500												
- 105 3090 32210500	105	31	2.1	46,500												
- 120 3090 32212000	120	46	2.3	47,500												
- 135 3090 32213500	135	61	2.5	48,000												
- 165 3090 32216500	165	91	2.8	49,500												
- 195 3090 32219500	195	121		50,500												

型式 Model	商品コード Code	Type	d	L	L ₁	L ₂	B	D	D ₁	L ₀	キャップ Nut	kg	-	コレット Collet	スパナ Spanner	レンチ Wrench
BT50	- 90	3090 50709000	0.5 ~7.0	90		36					HDP-07	3.8	42,500	FDC-07A	S-0	
	-105	3090 50710500		105		51						43,000				
	-120	3090 50712000		120	22~45	66		41	23			43,500				
	-135	3090 50713500		135		81						44,000				
	-165	3090 50716500		165		111						46,000				
	-195	3090 50719500		195		141						47,000				
	- 90	3090 50909000	2.5 ~9.0	90		36	0~4				HDP-09	3.8	42,500	FDC-09	S-1L	L-3T
	-105	3090 50910500		105		51						43,000				
	-120	3090 50912000		120	27~57	66		45	26			43,500				
	-135	3090 50913500		135		81						44,000				
	-165	3090 50916500		165		111						46,000				
	-195	3090 50919500		195		141						47,000				
	-225	3090 50922500	225		171					48,500						
	-255	3090 50925500	255		201					49,000						
	- 90	3090 51209000	2.5 ~12.0	90		32					HDP-12	4.0	45,000	FDC-12	S-3L	L-4T
	-105	3090 51210500		105	33~69	47	0~5	56	32			45,500				
	-120	3090 51212000		120		62						46,000				
	-135	3090 51213500		135		77						46,500				
	-165	3090 51216500		165		107						48,500				
	-195	3090 51219500		195		137						49,500				
	-225	3090 51222500	225		167					51,000						
	-255	3090 51225500	255		197					52,000						
	- 90	3090 51609000	3.5 ~16.0	90		32					HDP-16	4.1	46,000	FDC-16	S-4L	
	-105	3090 51610500		105	38~82	47	0~6	62	36			47,000				
	-120	3090 51612000		120		62						47,500				
-135	3090 51613500	135			77					48,000						
-165	3090 51616500	165			107					50,000						
-195	3090 51619500	195			137					51,000						
-225	3090 51622500	225		167					52,000							
-255	3090 51625500	255		197					53,500							
-105	3090 52210500	3.5 ~22.0	105		43					HDP-22	4.5	51,000	FDC-22	S-5L	L-5T	
-120	3090 52212000		120	47~103	58	0~8	76	46			52,000					
-135	3090 52213500		135		73						53,000					
-150	3090 52215000		150		88						54,000					
-165	3090 52216500		165		103						55,000					
-195	3090 52219500		195		133						56,000					
-225	3090 52222500	225		163					57,000							
-255	3090 52225500	255		193					58,500							

- コレット、スパナ、六角穴付プリセットスクリュー、セヨドライ加工用プリセットスクリュー、振れ調整レンチは別途ご注文下さい。標準仕様プリセットスクリューは付属しております。
- クーラントコレット（FDC-OH、C、MS）とタング付刃具併用時の最低挿入長はP89を参照下さい。
- L1はプリセットスクリューを使用した時の値です。

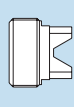
- Collet, spanner, hexagon head preset screw, preset screw for semi-dry processing, and adjustment wrench are sold separately. Standard preset screw is included.
- Refer to P89 for minimum tool insertion length in case of using our coolant collets (OH,C or MS).
- "L1" dimensions in brackets are for using preset screw.

	コレット Collet P84		スパナ Spanner P90		プリセット スクリュー Preset screw P91		振れ調整レンチ Adjustment wrench P90
---	-----------------------	---	-----------------------	---	---------------------------------------	---	-------------------------------------

ご注文例 Ordering Example

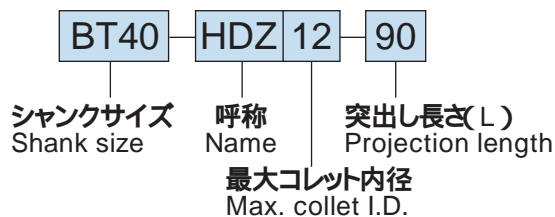



AHO "R"ゼロホルダ HDZ

"R"ZERO HOLDER

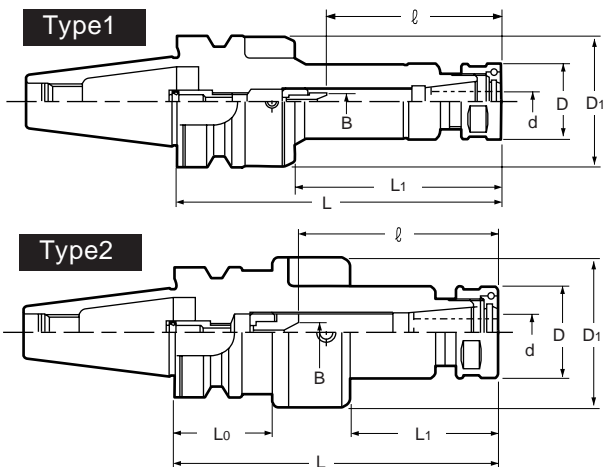

特長 Feature

刃先の振れを限りなく「ゼロ」に調整できる画期的なホルダです。

Runout accuracy of the cutting edge can be adjusted as closely as to zero.

AHO

⚠️ 当社規格2面拘束BT主軸(NBT-AHO対応)とBT2面拘束主軸(BBT-AHO対応)には互換性がありません。P22を参照ください。
Our two-face contact BT spindle (for NBT-AHO) is incompatible with BT two-face contact spindle (for BBT-AHO). Please refer to P22.

型式 Model	商品コード Code	Type	d	L	L ₁	ℓ	B	D ₁	D	L ₀	キャップ Nut	kg	-	コレット Collet	スパナ Spanner	
NBT-AHO30 or BBT-AHO30	-60 3840 0640000	1	0.5-7.0	60	22	22~23	0~4	41	23	-	HDP-07A	38,400	FDC-07	S-0		
	-75 3840 0650000			75	37	22~38									40,200	
	-90 3840 0660000			90	52	22~45									40,800	
	-105 3840 0670000			105	67	22~45									41,400	
	-75 3840 0680000	2	2.5-9.0	75	37	27~40	0~5	45	26	-	HDP-09	38,400	FDC-09	S-1L		
	-90 3840 0690000			90	52	27~50									40,200	
	-105 3840 0700000			105	67	27~50									40,800	
	-120 3840 0760000			120	82	27~57									42,000	
	-90 3840 0710000	2	2.5-12.0	90	33	33~55	0~5	52	32	-	HDP-12	42,000	FDC-12	S-3L		
	-105 3840 0720000			105	48	33~65									43,200	
	-120 3840 0770000			120	63	33~69									43,200	
	-90 3840 0730000			90	33	38~50									32	HDP-16
-105 3840 0740000	105	48	38~65	44,400												
-120 3840 0750000			120	63	38~80						45,600					
NBT-AHO40 or BBT-AHO40	-75 3840 0010000	1	0.5-7.0	75	32	22~38	0~4	41	23	-	HDP-07A	45,000	FDC-07	S-0		
	-90 3840 0020000			90	47										45,600	
	-105 3840 0030000			105	62	22~45									47,400	
	-120 3840 0780000			120	77	22~45									48,000	
	-135 3840 0790000			135	92	22~45									48,600	
	-90 3840 0040000			90	47	27~55									45,000	
	-105 3840 0050000			105	62	27~55									45,600	
	-120 3840 0060000			120	77	27~57									46,800	
	-135 3840 0070000			135	92	27~57									47,400	
	-165 3840 0080000			165	122	27~57									48,600	
	-90 3840 0090000			90	43	33~55									47,400	
	-105 3840 0100000			105	58	33~55									48,000	
	-120 3840 0110000	120	73	33~55	48,600											
	-135 3840 0120000	135	88	33~69	49,800											
	-165 3840 0130000	165	118	33~69	51,000											
	-195 3840 0140000	195	148	33~69	52,200											
	-90 3840 0150000	2	3.5-16.0	90	43	38~55	0~6	62	36	-	HDP-16	1.4	49,800	FDC-16	S-4L	
	-105 3840 0160000			105	58	38~70										50,400
	-120 3840 0170000			120	73	38~70										51,000
	-135 3840 0180000			135	88	38~82										51,600
	-165 3840 0190000			165	118	38~82										53,400
	-195 3840 0200000			195	148	38~82										54,600
	-105 3840 0210000			105	31	47~65										55,800
	-120 3840 0220000			120	46	47~80										57,000
-135 3840 0230000	135			61	47~95	57,600										
-165 3840 0240000	165			91	47~95	59,400										
-195 3840 0250000	195			121	47~103	60,600										

Rゼロホルダ



型式 Model	商品コード Code	Type	d	L	L ₁	ℓ	B	D ₁	D	L ₀	キャップ Nut	kg	-	コレット Collet	スパナ Spanner
-HDZ07	-90 3840 0260000	0.5~7.0	90	36	36	22~45	41	23	HDP-07A	FDC-07	S-0	51,000			
	-105 3840 0270000											51,600			
	-120 3840 0280000											52,200			
	-135 3840 0290000											52,800			
	-165 3840 0300000											55,200			
	-195 3840 0310000											56,400			
-HDZ09	-90 3840 0320000	2.5~9.0	90	36	27~50	0~4	45	26	HDP-09	FDC-09	S-1L	51,000			
	-105 3840 0330000											51,600			
	-120 3840 0340000											52,200			
	-135 3840 0350000											52,800			
	-165 3840 0360000											55,200			
	-195 3840 0370000											56,400			
	-225 3840 0380000											58,200			
	-255 3840 0390000											58,800			
NBT-AHO50 or BBT-AHO50	-90 3840 0400000	2.5~12.0	90	32	33~50	0~5	56	32	HDP-12	FDC-12	S-3L	54,000			
	-105 3840 0410000											54,600			
	-120 3840 0420000											55,200			
	-135 3840 0430000											55,800			
	-165 3840 0440000											58,200			
	-195 3840 0450000											59,400			
	-225 3840 0460000											61,200			
	-255 3840 0470000											62,400			
-HDZ16	-90 3840 0480000	3.5~16.0	90	32	38~50	0~6	62	36	HDP-16	FDC-16	S-4L	55,200			
	-105 3840 0490000											56,400			
	-120 3840 0500000											57,000			
	-135 3840 0510000											57,600			
	-165 3840 0520000											60,000			
	-195 3840 0530000											61,200			
	-225 3840 0540000											62,400			
	-255 3840 0550000											64,200			
-HDZ22	-105 3840 0560000	3.5~22.0	105	43	47~67	0~8	76	46	HDP-22	FDC-22	S-5L	61,200			
	-120 3840 0570000											62,400			
	-135 3840 0580000											63,600			
	-150 3840 0590000											64,800			
	-165 3840 0600000											66,000			
	-195 3840 0610000											67,200			
	-225 3840 0620000											68,400			
	-255 3840 0630000											70,200			





AHO

商品コードの はNBT-AHOでは0,BBT-AHOでは5となります。

- コレット、スパナ、セミドライ加工用プリセットスクリユ、振れ調整レンチは別途ご注文下さい。標準仕様プリセットスクリユは付属しております。
- クーラントコレット（FDC-OH、C、MS）とタング付刃具併用時の最低挿入長はP89を参照下さい。
- ℓ はプリセットスクリユを使用した時の値です。

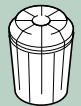
- Collet, spanner, hexagon head preset screw, preset screw for semi-dry processing, and adjustment wrench are sold separately. Standard preset screw is included.
- Refer to P89 for minimum tool insertion length in case of using our coolant collets (OH,C or MS).
- ℓ dimensions in brackets are for using preset screw.

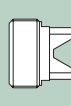
R
ゼ
ロ
ホル
ダ

	コレット Collet P84		スパナ Spanner P90		プリセット スクリユ Preset screw P91		振れ調整レンチ Adjustment wrench P90
---	-----------------------	---	-----------------------	---	--------------------------------------	---	-------------------------------------

ご注文例 Ordering Example

当社規格2面拘束BT主軸対応
Corresponding to our two-face contact BT spindle

NBT-AHO40 - **HDZ 12** - **90**
 AHOシャンクサイズ 呼称 最大コレット内径
 AHO Shank size Name Max. collet I.D.
 突出し長さ(L)
 Projection length

BT2面拘束規格対応
Corresponding to BT two-face contact spindle

BBT-AHO40 - **HDZ 12** - **90**
 AHOシャンクサイズ 呼称 最大コレット内径
 AHO Shank size Name Max. collet I.D.
 突出し長さ(L)
 Projection length

特殊品もご用命ください。

Specials on request





HSK・A "R"ゼロホルダ HDZ "R"ZERO HOLDER

特長 Feature

刃先の振れを限りなく「ゼロ」に調整できる画期的なホルダです。
Runout accuracy of the cutting edge can be adjusted as closely as to zero.

Type1

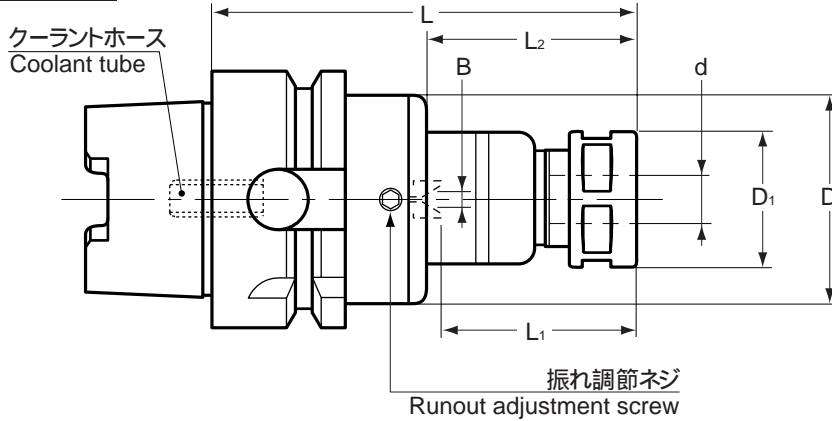

Type2

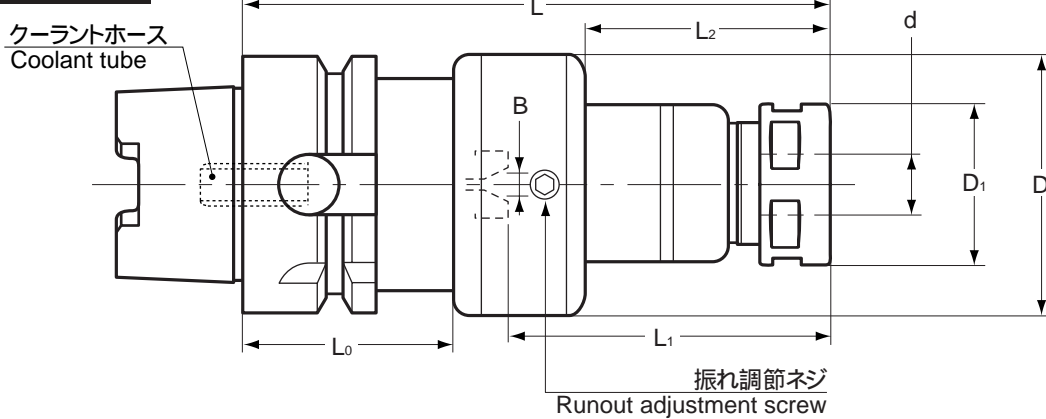

HSK・A

Rゼロホルダ

型式 Model	商品コード Code	Type	d	L	L ₁	L ₂	B	D	D ₁	L ₀	キャップ Nut	kg	-	コレット Collet	スパナ Spanner	レンチ Wrench
HSK40A	-75 5650 13007075	1	0.5	75	22~38	39					HDP-07A	43,500		FDC-07	S-0	L-3T
	-90 5650 13007090		~ 7.0	90	22~49	54	0~4	34	23			44,500				
	-120 5650 13007120		120	84						0.5		45,000				
	-90 5650 13009090	2	2.5	90	27~46	34			41	26	HDP-09	43,500		FDC-09	S-1L	L-3T
	-120 5650 13009120		~ 9.0	120	27~61	64				0.6		44,500				
	-90 5650 13012090		2.5	90	33~51	30						0.8	46,000			
	-120 5650 13012120	2	~ 12.0	120	33~74	60	0~5	52	32		HDP-12	46,500		FDC-12	S-3L	L-4T
	-150 5650 13012150		150	33~74	90							50,000				
	-90 5650 13016090		3.5	90	38~54	30						0.9	47,000			
	-120 5650 13016120		~ 16.0	120	38~72	60	0~6	56	36			1.1	49,000			
-150 5650 13016150			150	38~86	90						53,000					
HSK50A	-75 5650 14007075	1	0.5	75	22~32	33					HDP-07A	47,000		FDC-07	S-0	L-3T
	-90 5650 14007090		~ 7.0	90	22~45	48	0~4	41				0.7	48,000			
	-120 5650 14007120		120	22~45	78					0.8		48,500				
	-75 5650 14009075	2	2.5	75	27~31	33			41		HDP-09	46,000		FDC-09	S-1L	L-3T
	-90 5650 14009090		~ 9.0	90	27~47	48				0.7		47,000				
	-120 5650 14009120		120	27~61	78					0.8		48,000				
	-90 5650 14012090	2	2.5	90	33~42	23					HDP-12	49,000		FDC-12	S-3L	L-4T
	-120 5650 14012120		~ 12.0	120	33~71	53	0~5	52	32			1.2	50,000			
	-150 5650 14012150		150	33~74	83							1.4	52,500			
	-90 5650 14016090		3.5	90	38~50	23						1.1	54,500			
-120 5650 14016120	2	~ 16.0	120	38~65	53	0~6	56	36		HDP-16	55,500		FDC-16	S-4L	L-4T	
-150 5650 14016150		150	38~86	83					1.5		57,000					

特殊品もご用命ください。

Specials on request







型 式 Model	商品コード Code	Type	d	L	L ₁	L ₂	B	D	D ₁	L ₀	キャップ Nut	kg	-	コレット Collet	スパナ Spanner	レンチ Wrench	
HSK63A	-75	5650 15007075	0.5	75	22~35	33	0~4	41	23		HDP-07A	0.9	50,000	FDC-07	S-0	L-3T	
	-90	5650 15007090		90	22~45	48						51,500					
	-120	5650 15007120		120	27~48	78						52,500					
	-75	5650 15009075	1	2.5	75	27~34	33	45	26	-	HDP-09	1.0	50,000	FDC-09	S-1L		
	-90	5650 15009090			90	27~42	48					51,500					
	-120	5650 15009120			120	27~57	78					52,500					
	-90	5650 15012090	1	2.5	90	33~48	44	0~5	52	32	HDP-12	1.2	52,500	FDC-12	S-3L	L-4T	
	-120	5650 15012120			120	33~69	74					54,000					
	-150	5650 15012150			150	33~69	104					55,000					
	-90	5650 15016090	2	3.5	90	38~48	28	0~6	56	36	HDP-16	1.4	56,000	FDC-16	S-4L		
	-120	5650 15016120			120	38~62	58					57,500					
	-150	5650 15016150			150	38~82	88					58,500					
-120	5650 15022120	2	3.5	120	47~63	49	0~8	69	46	HDP-22	2.0	59,500	FDC-22	S-5L	L-5T		
-150	5650 15022150			150	47~93	79					61,500						
HSK100A	-75	5650 17007075	0.5	75	22~27	26	0~4	41	23		HDP-07A	0.9	57,500	FDC-07	S-0	L-3T	
	-90	5650 17007090		90	22~45	41						58,500					
	-120	5650 17007120		120	27~48	71						59,500					
	-75	5650 17009075	1	2.5	75	27~28	26	45	26	-	HDP-09	2.4	57,500	FDC-09	S-1L		
	-90	5650 17009090			90	27~47	41					58,500					
	-120	5650 17009120			120	27~57	71					59,500					
	-90	5650 17012090	1	2.5	90	33~41	41	0~5	56	32	-	HDP-12	2.6	59,500	FDC-12	S-3L	L-4T
	-120	5650 17012120			120	33~59	71						60,500				
	-150	5650 17012150			150	33~69	101						61,500				
	-90	5650 17016090	1	3.5	90	38~41	41	0~6	62	36	HDP-16	2.7	61,500	FDC-16	S-4L		
	-120	5650 17016120			120	38~62	71					62,500					
	-150	5650 17016150			150	38~82	101					63,500					
-90	5650 17022090	1	3.5	90	56	37	0~8	76	46	HDP-22	3.0	68,000	FDC-22	S-5L	L-5T		
-120	5650 17022120			120	47~59	67					69,000						
-150	5650 17022150			150	47~83	97					70,000						

HSK-A

- コレット、スパナ、六角穴付プリセットスクリュー、セミドライ加工用プリセットスクリュー、振れ調整レンチは別途ご注文下さい。標準仕様プリセットスクリューは付属しております。
- クーラントコレット（FDC-OH、C、MS）とタング付刃具併用時の最低挿入長はP288を参照下さい。
- L1はプリセットスクリューを使用した時の値です。

- Collet, spanner, hexagon head preset screw, preset screw for semi-dry processing, and adjustment wrench are sold separately. Standard preset screw is included.
- Refer to P288 for minimum tool insertion length in case of using our coolant collets (FDC-OH,C or MS).
- "L1" dimensions in brackets are for using preset screw.

	コレット Collet P284		スパナ Spanner P289		プリセット スクリュー Preset screw P290		振れ調整レンチ Adjustment wrench P289
---	------------------------	---	------------------------	---	--	---	--------------------------------------

ご注文例 Ordering Example

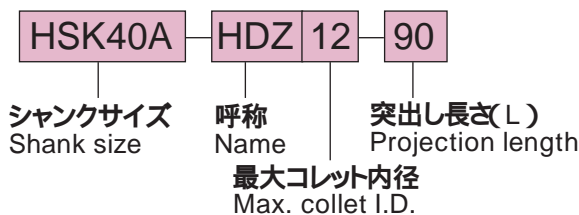

R
ゼ
ロ
ホル
ダ



UTS "R"ゼロホルダ HDZ "R"ZERO HOLDER

振れ調整ネジ
Runout adjustment screw

Type1

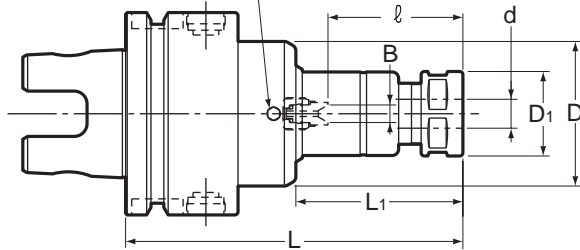

振れ調整ネジ
Runout adjustment screw

Type2

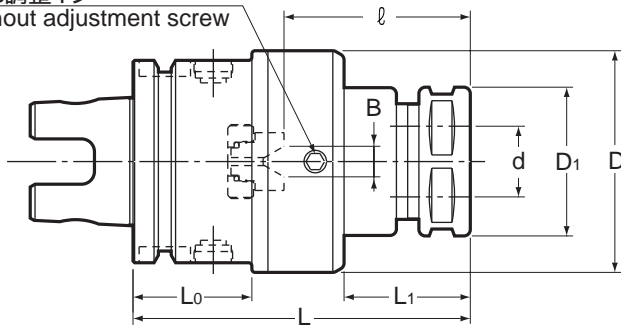

特長 Feature

刃先の振れを限りなく「ゼロ」に調整できる画期的なホルダです。
Runout accuracy of the cutting edge can be adjusted as closely as to zero.

型式 Model	商品コード Code	Type	d	L	ℓ	B	D	L ₁	L ₀	D ₁	キャップ Nut	kg	-	コレット Collet	スパナ Spanner	レンチ Wrench
UTS5040 (高圧用のみ High pressure only)	- 75-H 1250 01107075	1	75	22~32			29				HDP-07A	55,620	FDC-07	S-0	L-3T	
	-HDZ07 - 90-H 1250 01107090		0.5~7.0	90	22~45		44	23		56,860						
	-120-H 1250 01107120		120		74				57,470							
	- 75-H 1250 01109075	2	75	27~31	0~4	41	29	-			HDP-09	54,490	FDC-09	S-1L	L-3T	
	-HDZ09 - 90-H 1250 01109090		2.5~9.0	90	27~47		44	26		55,620						
	-120-H 1250 01109120		120	27~61		74			56,860							
	- 90-H 1250 01112090	2	90	33~41			35				HDP-12	57,990	FDC-12	S-3L	L-4T	
	-HDZ12 -120-H 1250 01112120		2.5~12.0	120	33~70	0~5	52	65	32			59,230				
	-150-H 1250 01112150		150	33~73		95			30	62,110						
	- 90-H 1250 01116090		90	38~49		35				64,480						
-HDZ16 -120-H 1250 01116120	2	3.5~16.0	120	38~64	0~6	56	65	36		HDP-16	65,710	FDC-16	S-4L	L-4T		
-150-H 1250 01116150		150	38~85		95			67,470								
UTS6350	- 75 1250 0 207075	1	75	22~34			26				HDP-07A	59,230	FDC-07	S-0	L-3T	
	-HDZ07 - 90 1250 0 207090		0.5~7.0	90	22~45		41	41	23	1.1		60,980				
	-120 1250 0 207120		120		71				1.2	62,110						
	- 75 1250 0 209075	1	75	27~34	0~4		26				HDP-09	59,230	FDC-09	S-1L	L-3T	
	-HDZ09 - 90 1250 0 209090		2.5~9.0	90	27~42		45	41	-	26		1.1				60,980
	-120 1250 0 209120		120	27~57		71			1.3	62,110						
	- 90 1250 0 212090	1	90	33~47			37				HDP-12	1.3	62,110	FDC-12	S-3L	L-4T
	-HDZ12 -120 1250 0 212120		2.5~12.0	120	33~69	0~5	52	67	32			63,960				
	-150 1250 0 212150		150		97				1.6	65,100						
	- 90 1250 0 216090		90	38~47		37			1.3	66,330						
	-HDZ16 -120 1250 0 216120	1	3.5~16.0	120	38~61	0~6	56	67	36		HDP-16	1.5	68,080	FDC-16	S-4L	L-4T
	-150 1250 0 216150		150		97	33		1.5	69,320							
- 90 1250 0 222120	2	3.5~22.0	120	47~62	0~8	69	58	46		HDP-22	2.0	75,190	FDC-22	S-5L	L-5T	
-150 1250 0 222150		150	47~92		88			2.0	88,270							

特殊品もご用命ください。

Specials on request



UTS

Rゼロホルダ

